

# Masport®

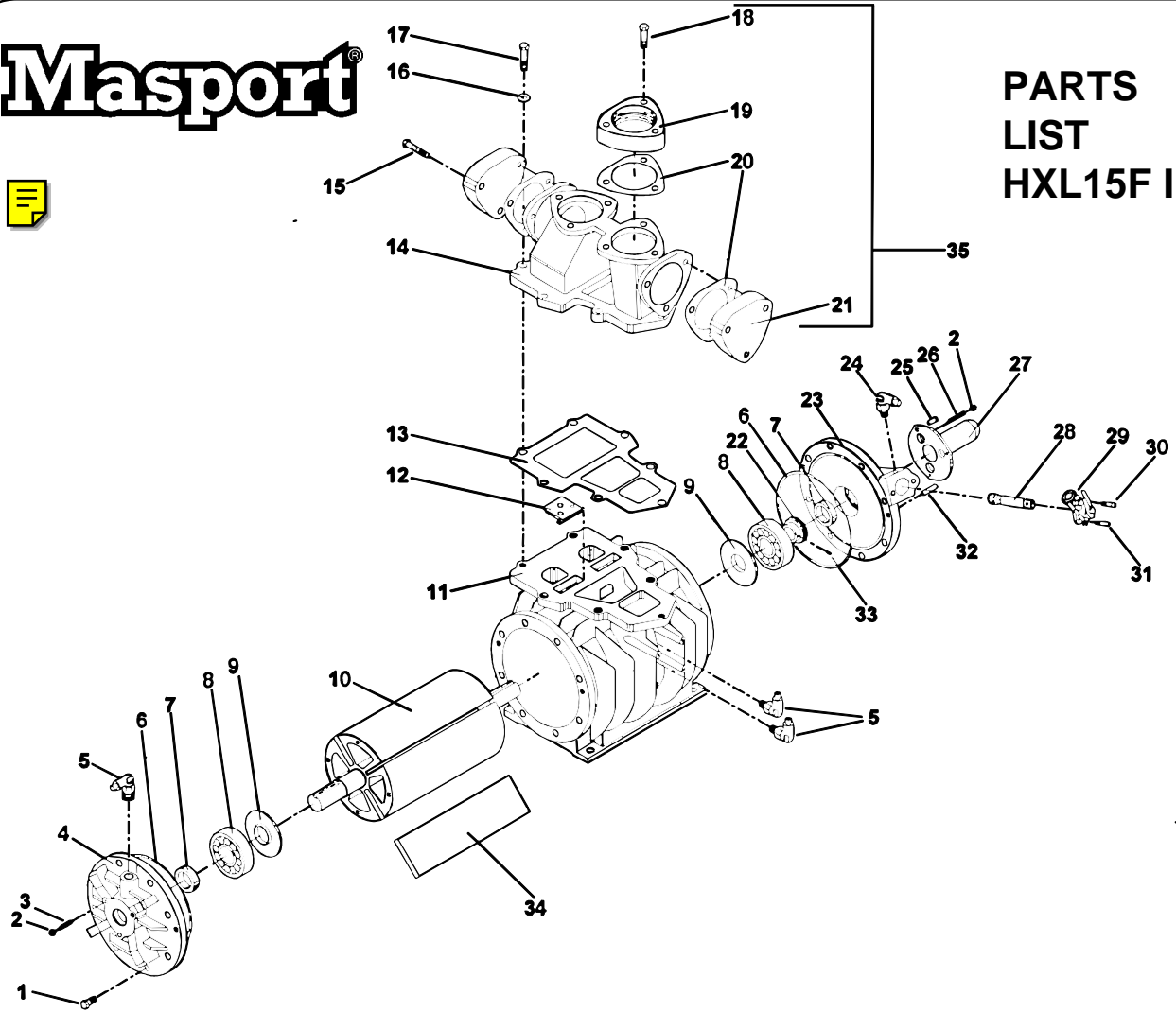

## PARTS LIST HXL15F II



### HXL15F SERIES II AIR COOLED VACUUM / PRESSURE PUMP PARTS LIST (968885)

Ref	Description	Part No.	Qty.	Ref	Description	Part No.	Qty.
1	Bolt	501569	16	21	Blank Flange Plate	975397	2
2	Nut	504278	6	22	Gear	568158	1
3	Set Screw	504276	3	23	Endcover	968854	1
4	Endcover	968843	1	24	Swivel Elbow	568085	1
5	Swivel Elbow	568086	3	25	Bolt	501571	3
6	O-Ring	501677	2	26	Set Screw	504277	3
7	Oil Seal	501015	2	27	Shaft Guard	568622	1
8	Bearing	503098	2	28	Drive Shaft Assembly	968045	1
9	Bearing Spacer	968611	2	29	Oil Pump	575437	1
10	Rotor Assembly (Incl. 8, 9)	968848	1	30	Cap Screw	504262	1
11	Cylinder	968881	1	31	Cap Screw	504261	1
12	Flap Assembly	968026	2	32	Dowel Pin	503258	4
13	Gasket	568884	1	33	Set Screw	504264	1
14	Manifold	975398	1	34	Vane	968811	4
15	Bolt	501752	6	35	4-Port Flange Assembly	975382	1
16	Washer	500203	7		(Incl. 14,15,18,19,20,21)		
17	Bolt	501666	7	36	Endcover Shim Gasket *		
18	Bolt	543627	6		.002" Thickness	542011	**
19	Flange	975396	2		.003" Thickness	542012	**
20	Gasket	575381	4				

\* NOT SHOWN.    \*\* QUANTITY VARIES.