

ITK 20 Model SLIDING ARM AND ARTICULATED JIB SERIES

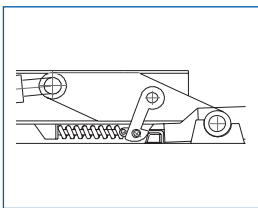

Key Features



Auto centre body lock.

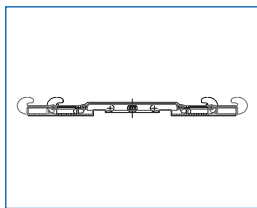

External hydraulic locking standard.

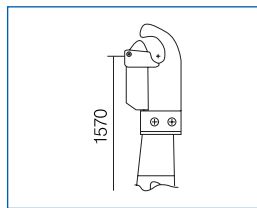

Standard with pneumatic hook safety latch.

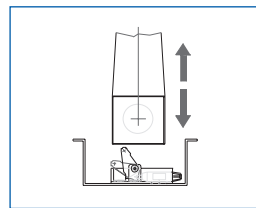

Automatic interlock system.

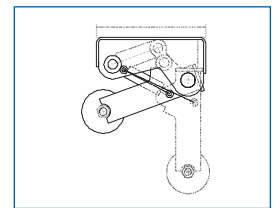

Various optional stabilisers.

Standard Features

- Articulating and sliding Jib
- External locks
- Automatic centre body lock
- Standard pneumatic hook safety lock
- Automatic bin clamp lockout when tipped
- Bolted hook

Optional Extras

- Internal hydraulic locking
- Front hydraulic locking
- Additional hydraulic circuit with cab control
- Suspension stabiliser
- Folding stabiliser
- Vertical stabiliser

ITK 20 Model SLIDING ARM AND ARTICULATED JIB SERIES

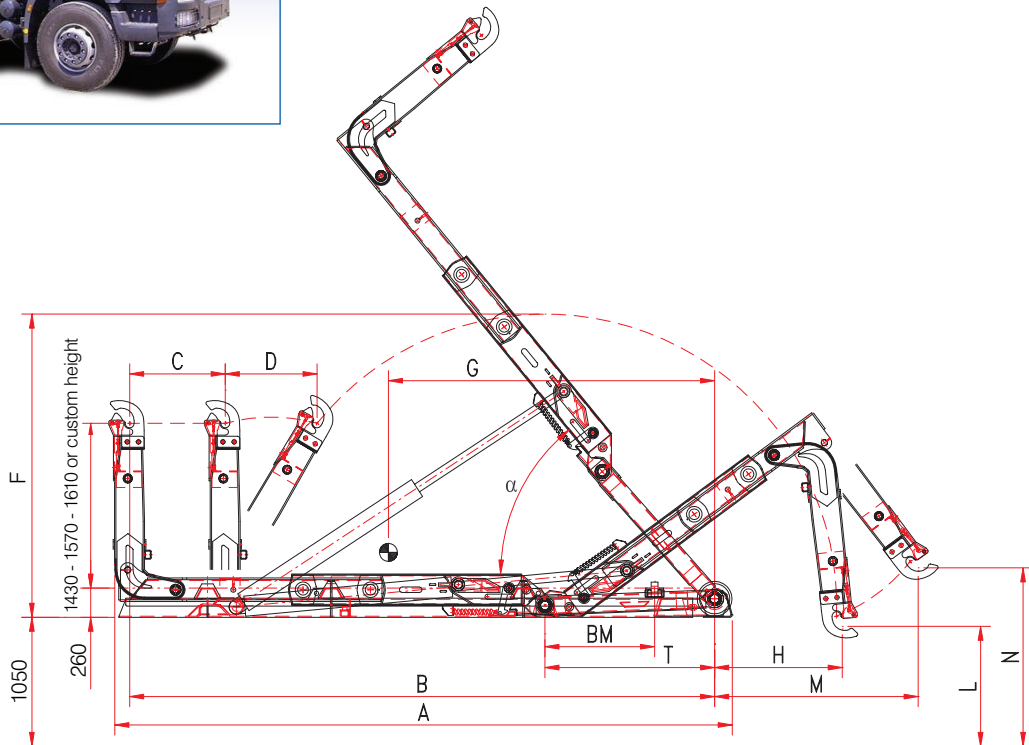

Models and Specifications

	A	B	C	D	F	G	H	BM	L	M	N	T	Weight	Tipping
ITK 20/6 C*	5.100	4.800	650	850	2.700	2.850	1.340	880	970	2.000	1.490	1.310	2.720	54°
ITK 20/6 NC	5.300	5.000	850	850	2.700	2.900	1.340	880	970	2.000	1.490	1.310	2.720	54°
ITK 20/6 N	5.500	5.200	850	850	2.700	3.000	1.140	980	970	1.800	1.490	1.510	2.750	51°
ITK 20/6 NL	5.700	5.400	850	850	2.700	3.100	940	980	970	1.600	1.490	1.710	2.780	48°
ITK 20/6 L	5.900	5.600	850	850	2.700	3.200	740	1.080	970	1.400	1.490	1.910	2.810	45°

* Standard Model

THE VACLIFT COMMITMENT

- Quality product
- Outstanding value
- Professional service
- World class design and construction

Phone 03 9339 9999
 Fax 03 9338 9540
 Email info@icaust.com

39 Tullamarine Park Rd,
 Tullamarine, Victoria 3043
 website: www.icaust.com

Vaclift provides the information contained herein in good faith, based upon the right to change specifications without notice. However, Vaclift accepts no liability, either direct or indirect for any loss or consequential loss that may result from the application of this information. Purchasers must conduct their own enquiries to ensure that the products are suitable for their own particular purposes. Photographs may show equipment that is available at extra cost. Vaclift Pty Ltd. ABN 45 004 743 748 Printed 10/07 VAC 010